



AWEX

Air/water heat exchangers Scambiatori di calore aria/acqua

FLUID COOLERS
SPECIAL COOLING APPLICATIONS
REFRIGERATORI PER FLUIDI
APPLICAZIONI FRIGORIFERE
SPECIALI

CERTIFIED COMPANY



Technical data Caratteristiche tecniche

			7.5	16	16 S
Nominal cooling capacity (*) Potenza frigorifera nominale (*)	W		1080	2040	3170
Nominal cooling capacity (**) Potenza frigorifera nominale (**)	W		2450	4590	7133
Installed power Potenza installata	W		300	800	800
Power supply Alimentazione elettrica			230V - 1ph - 50/60Hz		230V - 1ph - 50Hz (***)
Heat exchanger Scambiatore di calore			Air-cooled heat exchanger (copper/aluminium) Scambiatore di calore in rame/alluminio, raffreddato ad aria		
Pump Pompa	Flow rate (****) Portata (****)	l/min	0.25 - 8		5 - 30
	Head Prevalenza	bar	3.5 - 0.5		3.0 - 0.5
Hydraulic fittings Attacchi idraulici	gas F		1/4"		3/8"
Tank Serbatoio	l		5		8
Steel frame Struttura in lamiera di acciaio			Epoxy paint powder RAL 9005 Verniciatura RAL 9005		Epoxy paint powder RAL 1013 Verniciatura RAL 1013
Dimensions Dimensioni	mm		510x343x232h		520x310x675h
Weight (approx.) Peso indicativo	kg		12.8		27
Max. working temperature Massima temperatura di utilizzo	°C		+60		

Notes (*) Reference values: air +32°C, water +40°C. (**) Reference values: air +32°C, water +50°C. (***) 50/60Hz available on demand. (****) Flow rate referred to pure water.

Note (*) Valori di riferimento: aria +32°C, acqua +40°C. (**) Valori di riferimento: aria +32°C, acqua +50°C. (***) Su richiesta disponibile 50/60Hz. (****) Portata riferita ad acqua pura.

Available accessories:

(*) High pressure pump

Flow rate 2 - 15 l/min
Head 8 - 1 bar
Abs. power 750 W
Flow rate referred to pure water

Alarm flow switch

Water filter

(*) Mechanical thermostat fan command

(*) Electrical connector

Accessori disponibili:

(*) Pompa alta pressione:

Portata 2 - 15 l/min
Prevalenza 8 - 1 bar
Pot. ass. 750 W
Rese riferite ad acqua pura

Flussostato di allarme mancanza flusso

Filtro acqua

(*) Termostato meccanico di comando ventilatore

(*) Connettore elettrico di collegamento

(*) Only for models 16 and 16 S.

(*) Solo per i modelli 16 e 16 S.

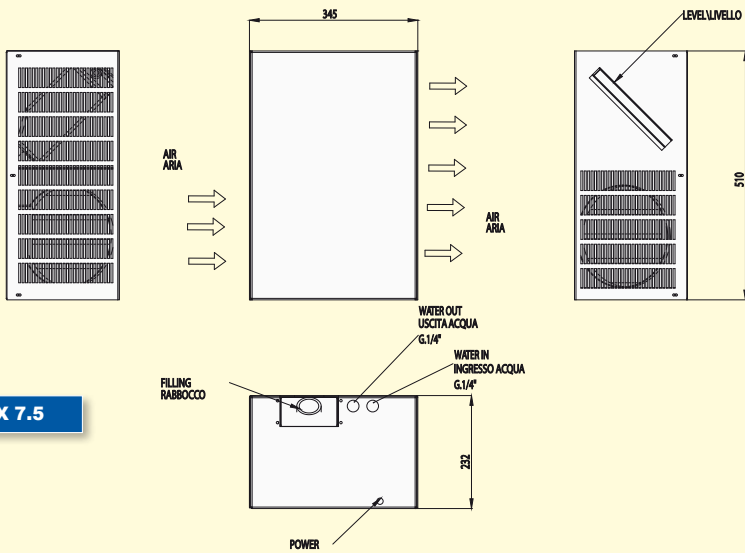

AWEX 7.5

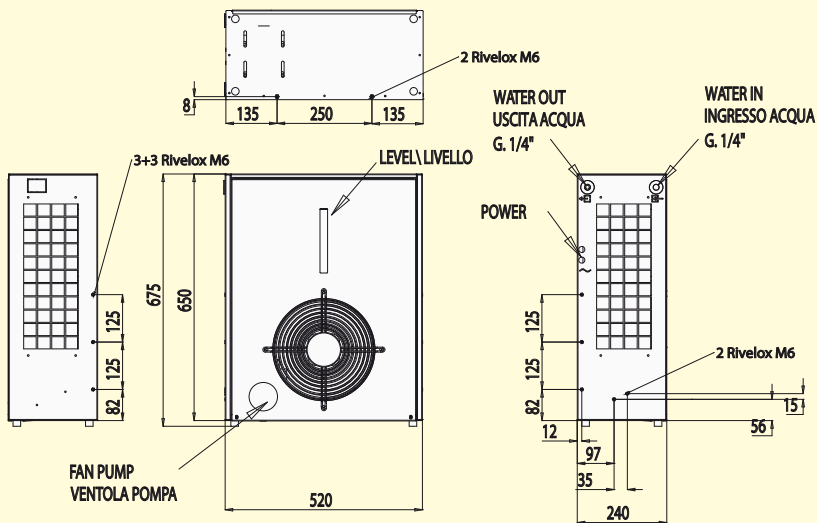

AWEX 16

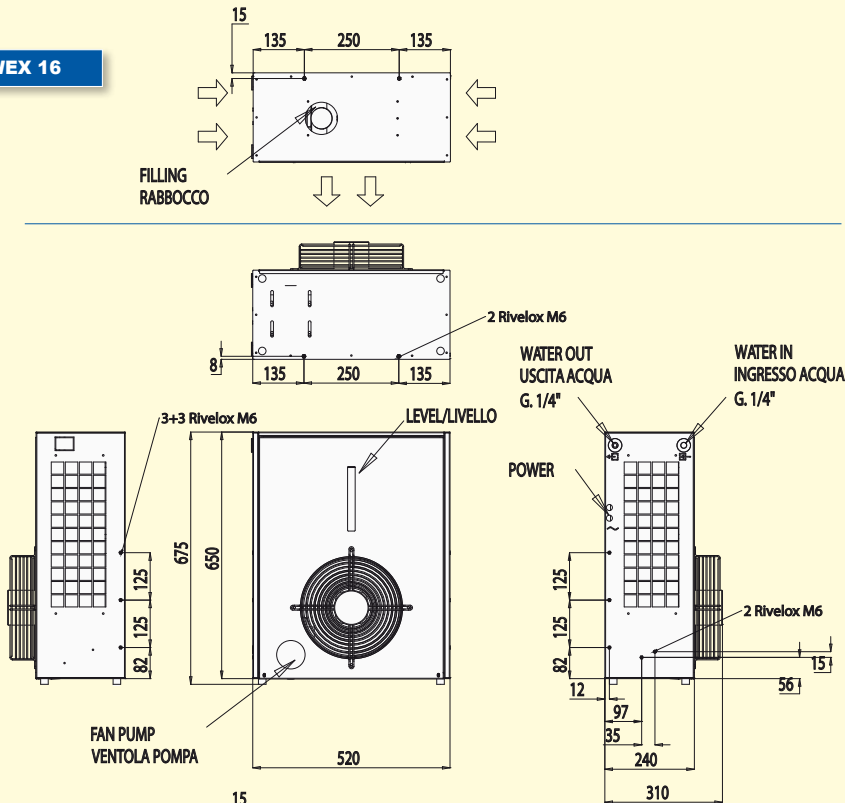

AWEX 16 S

Air/water heat exchangers
Scambiatori di calore aria/acqua

AWEX



EURO COLD srl
Via Aldo Moro, 11/E
41030 Bomporto (MO) Italy
Tel. +39.059.817. 8138
Fax +39.059.817.0482
www.eurocold.it
info@eurocold.it

All equipment produced by EURO COLD is covered by a product liability insurance worldwide. EURO COLD reserves the right to carry out modifications without prior notice.

EURO COLD si riserva il diritto di apportare modifiche senza obbligo di preavviso. Ogni apparecchiatura prodotta da EURO COLD è coperta da polizza assicurativa "RC Prodotti" in tutto il mondo.